

This article was downloaded by:

On: 28 January 2011

Access details: *Access Details: Free Access*

Publisher *Taylor & Francis*

Informa Ltd Registered in England and Wales Registered Number: 1072954 Registered office: Mortimer House, 37-41 Mortimer Street, London W1T 3JH, UK

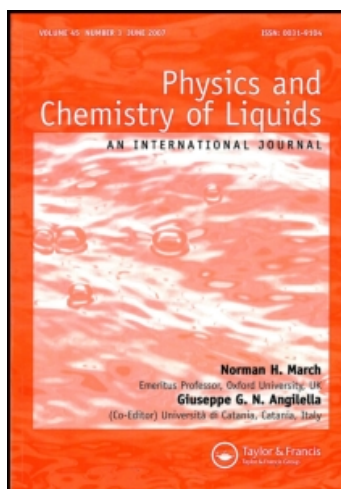

Physics and Chemistry of Liquids

Publication details, including instructions for authors and subscription information:

<http://www.informaworld.com/smpp/title~content=t713646857>

Sound Propagation in Thixotropic Structures

F. Aliotta^a; M. E. Fontanella^a; S. Magazu^a; F. Wanderlingh^b

^a Istituto di Tecniche Spettroscopiche dei CNR, S. Agata, Messina, Italy ^b Dipartimento di Fisica, dell'Università di Messina, S. Agata, Messina, Italy

To cite this Article Aliotta, F. , Fontanella, M. E. , Magazu, S. and Wanderlingh, F.(1991) 'Sound Propagation in Thixotropic Structures', *Physics and Chemistry of Liquids*, 23: 3, 163 – 173

To link to this Article: DOI: 10.1080/00319109108027253

URL: <http://dx.doi.org/10.1080/00319109108027253>

PLEASE SCROLL DOWN FOR ARTICLE

Full terms and conditions of use: <http://www.informaworld.com/terms-and-conditions-of-access.pdf>

This article may be used for research, teaching and private study purposes. Any substantial or systematic reproduction, re-distribution, re-selling, loan or sub-licensing, systematic supply or distribution in any form to anyone is expressly forbidden.

The publisher does not give any warranty express or implied or make any representation that the contents will be complete or accurate or up to date. The accuracy of any instructions, formulae and drug doses should be independently verified with primary sources. The publisher shall not be liable for any loss, actions, claims, proceedings, demand or costs or damages whatsoever or howsoever caused arising directly or indirectly in connection with or arising out of the use of this material.

SOUND PROPAGATION IN THYXOTROPIC STRUCTURES

F. ALIOTTA, M. E. FONTANELLA, S. MAGAZU

*Istituto di Tecniche Spettroscopiche dei CNR, Contrada Papardo,
I-98166 S. Agata (Messina), Italy.*

and

F. WANDERLINGH

*Dipartimento di Fisica dell'Università di Messina, Contrada Papardo,
I-98166 S. Agata (Messina), Italy.*

(Received 12 June 1990)

Mandelstam–Brillouin measurements on lysozyme 10% by weight aqueous solutions as a function of the exchanged wavevector k are presented.

The hypersonic velocity values, that result greater than those relative to “bulk” water, indicate a greater rigidity of the system for the k values corresponding to the maxima of the structure factor.

Such vibrational thermal excitations are hypothesized to be originated by the existence of a long ranged thyxotropic structure, that can exhibit a solid-like behaviour, provided that the strains do not exceed some limiting values.

KEY WORDS: Macromolecular solutions, Brillouin scattering.

1 INTRODUCTION

Some years ago, rheological measurements performed in macromolecular solutions^{1,2} showed the existence of long-ranged structures, that exhibit a thyxotropic behaviour. Shear stress is no longer proportional to shear rate, the usual value of viscosity ($\sim 10^{-2}$ poise) being reached only at high enough shear rate. In addition, the solutions are characterized by a yield-point, i.e. a non zero shear stress at zero shear rate. Structures build up gradually in the course of time, becoming fully developed after about ten hours, and can be suddenly destroyed when the sample is mechanically shaken.

Optical measurements allowed us to investigate the kind of structure, that turns out to be given by high-concentration regions (clusters), sized some hundreds of Å, that order themselves in space. The existence of a preferred cluster-cluster spacing

of some thousands of Å was also revealed. Moreover the diffusive properties of the system are strongly influenced by such a local structure as shown by quasi-elastic light scattering results (correlation technique). In particular the diffusion coefficient turns out to be wave-vector dependent, through the relation³

$$D = \frac{D_0}{S(k)}$$

where the structure factor, $S(k)$, reflects the existence of the preferred distances^{2,4}.

A theoretical model, analytically soluble, can adequately describe the observed behaviour⁵ both from a static and a dynamic point of view. It was argued that the above mentioned peculiarities could be of relevant interest for a deeper understanding of biological processes, like enzymatic catalysis, especially as far as the energy exchange between proteins and the surrounding bath is concerned⁶. In addition, recent neutron scattering experiments⁷ showed that there exists a coupling between the structure and the vibrational properties of water, even for the high-frequency O–H stretching band.

In such kind of experiments, the coupling is revealed by an increase of the “effective mass” that must be attributed to the scatterers (i.e. hydrogen atoms) in order to explain the observed spectral behaviour. Such an increasing, as well as the decreasing of the overall scattered intensity, can be related to a reinforcement of the network of hydrogen bonds involving a sizeable amount of water molecules. It is therefore expected that also the high frequency sound waves (Brillouin waves) could be influenced by the presence of the structure, especially in the case in which the acoustic wave-length matches with the “preferred distances” of the system.

In order to explore such a possibility, we performed an experiment in which the Brillouin shift is measured at different values of the scattered wave-vector (covering the range of interest) in a 10% by weight lysozyme solution.

The experiment is rather complicated due to the very intense elastic scattering, that makes difficult a detailed investigation of the Brillouin doublet.

However, despite such an inconvenience, the frequency shift ω_B associated with thermally excited librational modes can be measured quite accurately.

If one defines an “hypersonic velocity”, $c = \omega_B/k$, it turns out that this strongly depends on the exchanged wave-vector, becoming noticeably larger for the k -values that characterize the peaks in the structure factor, $S(k)$, of the solution. The increase is very large, up to the 60%, and well above the experimental uncertainty.

In Section 2 we describe the experimental procedure and report the obtained results. In Section 3 the observed phenomenon is discussed, also in comparison with other experimental results in the same system.

As a rather well supported hypothesis, we suggest that hypersonic excitations could be sustained by the “solid-like” thixotropic structure, provided that a matching exists between the acoustic wave-vector and the reciprocal lattice that characterizes the structure. It is in fact possible to show that, together with the faster propagation, there exists also a less intense sound wave that propagates slower, with a velocity near to the usual value of $1.5 \cdot 10^5$ cm/sec.

2 EXPERIMENTAL PROCEDURE AND RESULTS

We used a Tropel Model 350, piezoelectrically scanned, plane Fabry-Perot interferometer. Whole the experimental set-up was driven by a microcomputer PC/XT. Data were collected by the same microcomputer from a cooled photomultiplier (RCA c 31034) with a dark count rate lower than 10 counts/sec.

In order to avoid unwanted effects induced by intensity fluctuations of the probe, the intensity of the laser (Spectra Physica mod.170 with intercavity etalon) was monitored during each run and data from photomultiplier were normalized to it.

Samples were put on a goniometric unit that allowed changes of the scattering geometry with a good precision lecture of the scattering angle. The experimental set-up is schematically shown in Figure 1. The scattering wave-vector was selected both by changing the incident wave-length (4727 Å, 4880 Å and 5145 Å) and the scattering angle (between 30° and 90°).

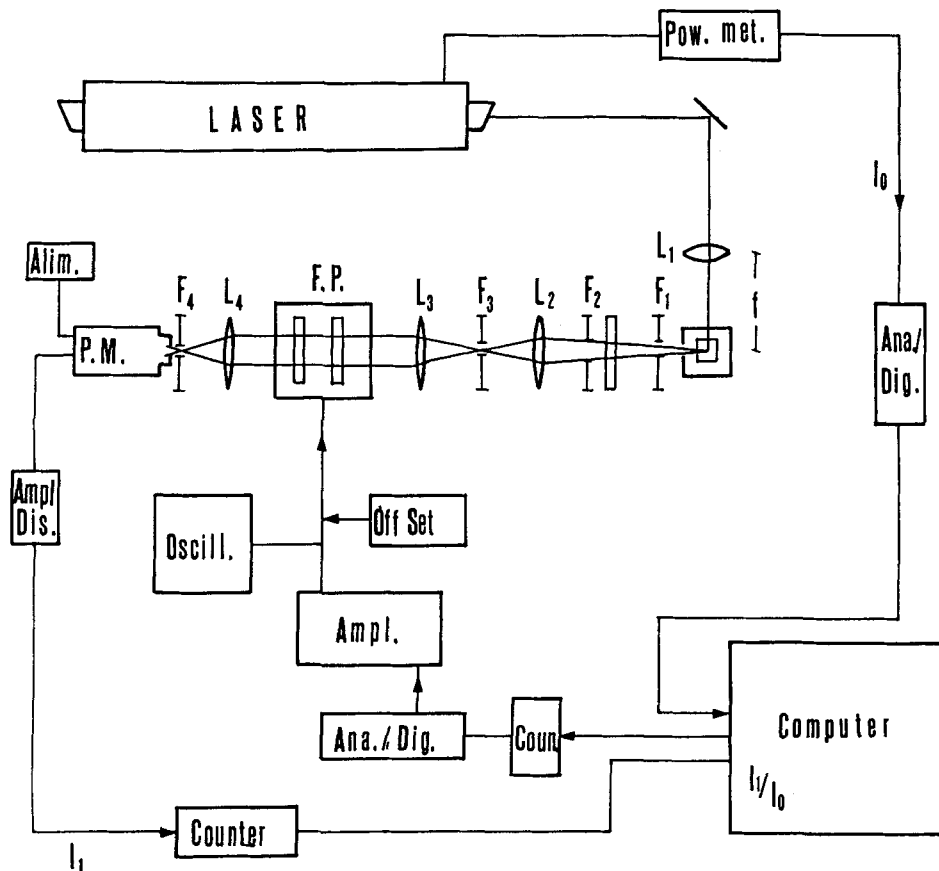

Figure 1 Experimental set-up. F = pinhole, L = lens, F.P. = Fabry-Perot interferometer, P.M. = photomultiplier.

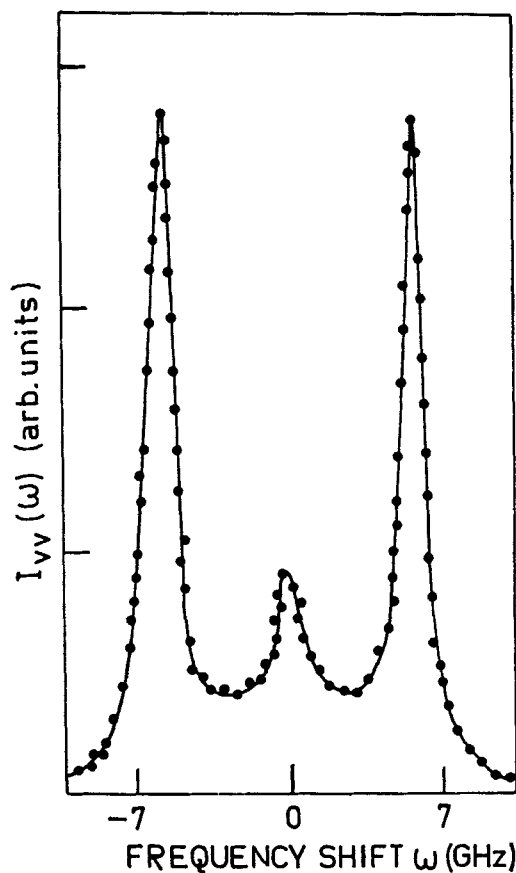

Figure 2 Mandelstam-Brillouin spectrum in water at 90° of scattering angle and at temperature $T = 20^\circ\text{C}$, F. S. R. (Free Spectral Range) = 8.12 GHz.

At each measurement a careful alignment was checked, and the free spectral range of the interferometer was adjusted in order to obtain the best resolution.

The sample was a 10% by weight lysozyme solution, prepared according to the same procedure used in our previous works. High purity lysozyme, purchased from Miles Lab. Inc. was dissolved in doubly distilled water. The obtained solution had a $\text{pH} = 5$, and no further adjustments were performed. Measurements started a long time after the preparation of the sample, in order to allow a full developing of the structure.

In Figure 2 we report, for a comparison, a Brillouin spectrum obtained for the pure water. In the case of the solution under investigation the obtained spectra are of less quality, mainly because of the intense elastic scattering that characterizes the macromolecular solutions.

In order to be able to detect with a sufficient accuracy the Brillouin peaks, a careful

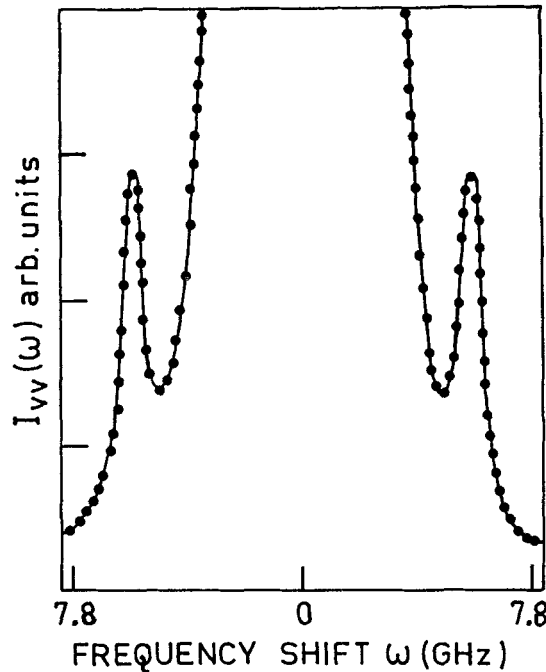

Figure 3 Typical Mandelstam-Brillouin spectrum in lysozyme aqueous solution at 80° of scattering angle and for $\lambda = 4880 \text{ \AA}$ with F. S. R. = 15 GHz.

adjustment between the Brillouin shift and the free spectral range is required. A typical spectrum is shown in Figure 3.

The spectrum of quasi-elastically scattered light can be described as the sum of three contributions⁸, namely the so-called Rayleigh (diffusive) line, centered at zero frequency shift, the Brillouin lines centered at a frequency shift ck and two skew lines centered at the same frequency shift⁹.

However, because of the very intense elastic contribution, the quality of our spectra do not allow such a detailed analysis, so that we limit ourselves to find the values of the Brillouin shift, ω_B , defined as the frequency corresponding to the maximum of the two non-central lines (i.e. the contribution of both the symmetric and skew lines, above mentioned), that is a rather common procedure in such kind of measurements. Obviously in such a case, the actual meaning of the "phase velocity" $c = \omega_B/k$ is to be clarified, as we shall see in the next Section. Despite the noisy of the experimental data, the values of ω_B can be obtained with enough accuracy, if one compares contributions of spectra belonging to two contiguous orders. We also tested the adequacy of our data analysis by comparing results obtained, for a given value of k , in different runs performed on the same sample.

In Figure 4 we report the obtained results. It can be seen that in the structured solutions, sound velocity strongly depends on the wave-vector k passing from values slightly different from those of pure water at large k ($c = 1480 \cdot 10^2 \text{ cm/sec}$) to

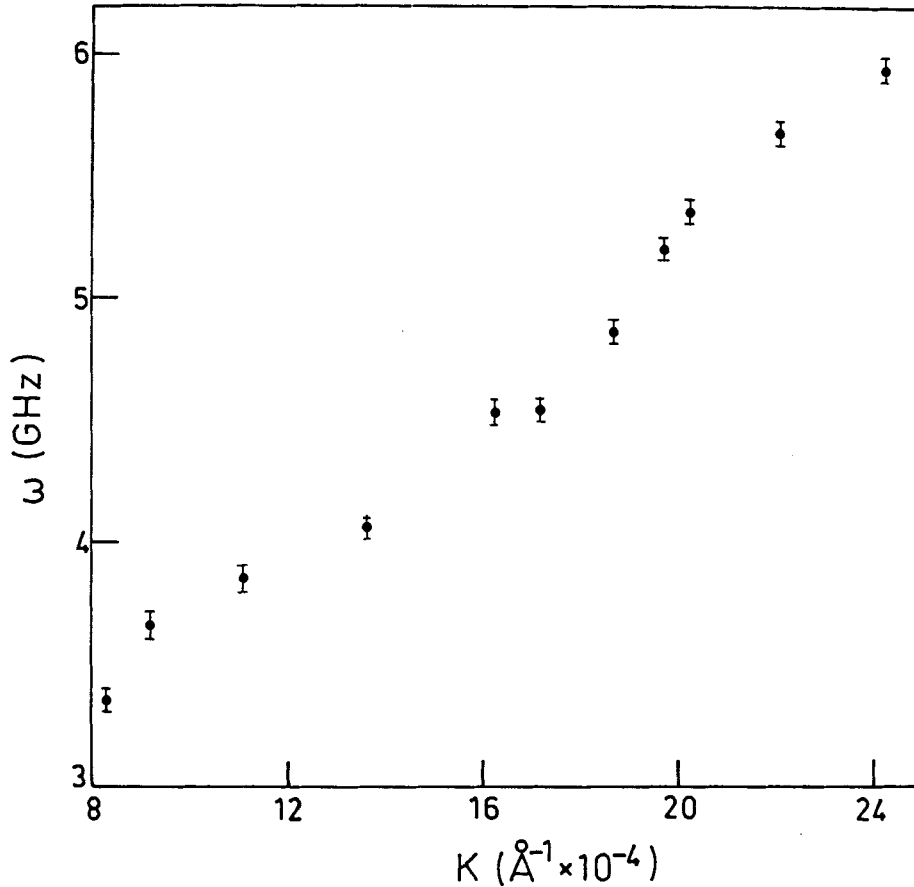

Figure 4 Frequency shift values ω , with relative error-bars, as a function of the exchanged wavevector k .

noticeable larger values at small k . In addition the behaviour of $c(k)$ seems to reproduce the one of the structure factor $S(k)$, as we shall see in the next Section.

3 DISCUSSION OF EXPERIMENTAL RESULTS

In Figure 5 we show a comparison between the present acoustic measurements, the experimental structure factor, as given by elastic light scattering and the theoretical $S(k)$ calculated according to the model of Ref. 5. It is quite evident that sound velocity (in the proper k -range) behaves exactly as the structure factor, that is the Fourier transform of the concentration-concentration autocorrelation function. As mentioned in Section 1, rheological measurements showed that the structure, built up by concentration fluctuations, is quite stable and is characterized by a solid-like behaviour, at least as far as small enough strains are concerned. There is, in fact, evidence that shear strains less than 10^3 dyn/cm² (Yield-Point) originate an "elastic"

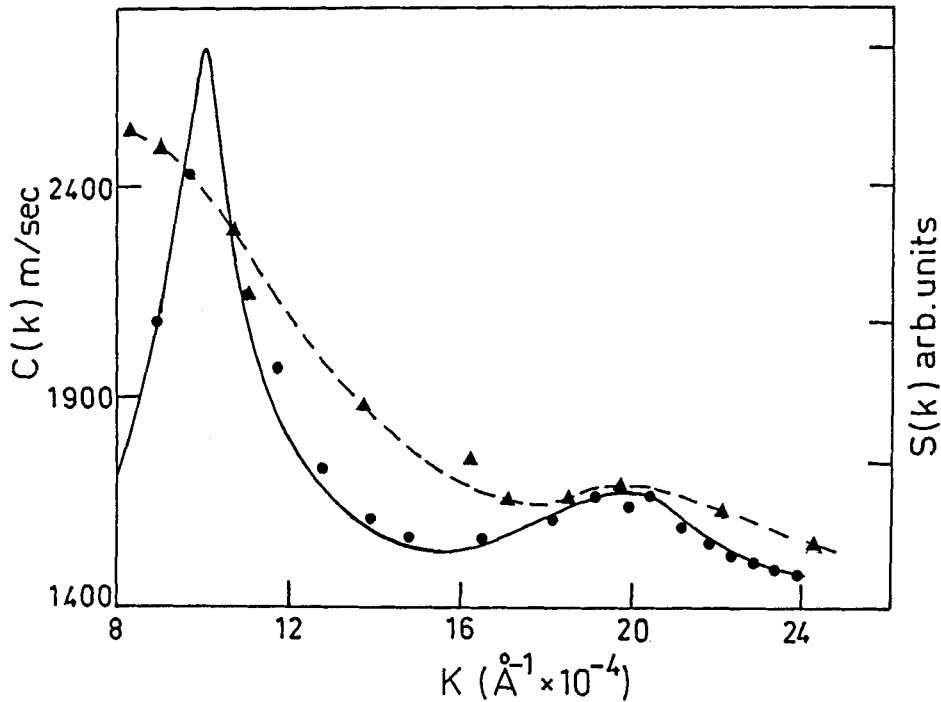

Figure 5 Hypersonic velocity $c(k)$ (▲) and Structure factor $S(k)$ (●) as a function of the exchanged wavevector. — theoretical curve. - - - guide for the eye.

deformation of the structure rather than a flow. The same indication comes from the experimental measurement of the diffusion coefficient^{2,4}, D , that turns out to be notably smaller than that found in literature, for unstructured (infinite dilution) solutions. In addition the diffusion coefficient depends on the exchanged wave-vector k according to the semiphenomenological relation $D = D_0/S(k)$. In other words, the mean life of the concentration fluctuations is greatly increased for some Fourier components, that, as a consequence, dominate in the spectrum giving rise to a well defined structure factor. The model proposed in Ref. 5 gives account for the observed behaviour in terms of a preferred inter-cluster distance that the system tends to maintain against thermal stochastic disturbances.

In order to discuss the present experimental results, one must take into account that in our sample the overwhelming contribution to the scattered intensity comes from large macromolecules. Therefore, actually we detect thermal excitations (Brillouin waves) as experienced by the thyxotropic structure.

Here we want to stress the fundamental difference between usual ultrasonic experiments and Brillouin scattering. As pointed out by Evans and Powles⁸ a damped oscillation obeys to the equation:

$$\frac{\partial^2 \xi}{\partial t^2} + \delta \frac{\partial \xi}{\partial t} - c^2 \frac{\partial^2 \xi}{\partial x^2} = 0 \quad (1)$$

where δ is the damping constant and c^2 is the ratio between a modulus and a density, c being usually interpreted as a velocity. From the above equation a dispersion relation can be deduced:

$$\omega^2 - i\delta\omega - c^2k^2 = 0 \quad (2)$$

Now, in an ultrasonic experiment ω is fixed, and then must be real, while a complex value for k describes a wave decaying in space. On the contrary, as far as Brillouin scattering is concerned, the wave-vector k is imposed by experimental conditions, so resulting real, and the complex frequency ω describes a standing wave decaying in time. Although the phenomenon can be treated in terms of propagating waves, travelling in opposite directions, the phase velocity turns out to be different than the "ultrasonic" one, having quite different meaning.

Really in our experiment the detected intensity mainly comes from fluctuations of the dissolved macromolecules' concentration rather than from overall density fluctuations. Obviously a fluctuation of the overall density could also imply a local fluctuation of concentration (defined as the number of macromolecules for unit volume) so that we are left, in principle, with two possible interpretations of our experimental data:

i) We are concerned with usual Brillouin waves, i.e. adiabatic pressure fluctuations, driving the dynamics of the dissolved macromolecules, that, in a sense, behave like an optical probe, due to their intense scattering.

ii) We are looking at vibrational thermal excitations belonging to the long ranged thixotropic structure, that exists in such kind of systems. As mentioned in Section 1 such a structure can exhibit a solid-like behaviour, provided that the strains do not exceed some limiting values. From a thermodynamic point of view, the two possibilities correspond to the attribution of the Brillouin peaks either to adiabatic fluctuations of pressure or to adiabatic fluctuations of chemical potential.

In the first case the spectrum of the scattered light concerns the $S_{\rho\rho}(k, \omega)$ i.e. the Fourier transform of the space-time density-density correlation function. In the second case the implied correlation must refer to the spatial concentration of macromolecules. Actually we believe that the most correct interpretation of our experimental results lies in the second point of view.

Recent neutron scattering experiments⁷ revealed in fact that only the 25% of the total amount of water in the solution is sizeable affected by the presence of the structure built up by the macromolecules. On the contrary, the first point of view requires that whole the system severely modifies, at least for that dynamical compressibility is concerned: in order to justify the observed increase of sound velocity, this latter quantity should increase of a factor 2.7. It is also to be mentioned that there are experimental evidence of the existence of weak additional peaks, in the spectra of scattered light, at frequencies corresponding to the usual value of sound velocity in water. Although such a feature is partially masked by the intense Rayleigh scattering of lysozyme, its existence seems unquestionable, being systematically present in each spectrum at the right place and clearly visible in correspondence to some values of the exchanged wavevector (see Figure 6 as an example). In addition,

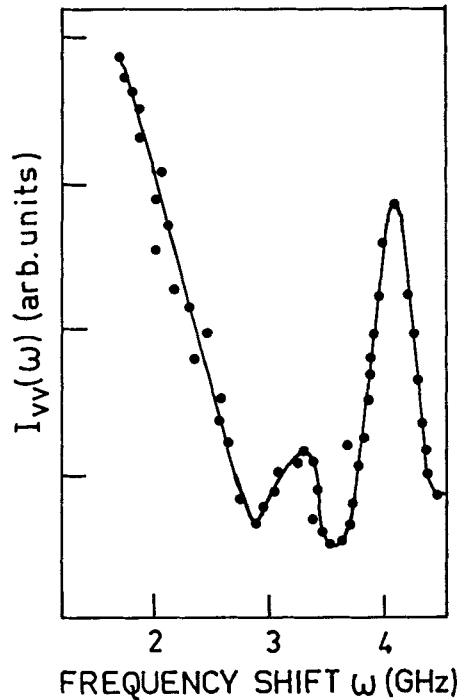

Figure 6 Brillouin spectrum of aqueous lysozyme solution for $k = 13.72 \cdot 10^4 \text{ cm}^{-1}$ ($\theta = 50^\circ$, $\lambda = 5145 \text{ \AA}$ and F. S. R. = 9 GHz.)

acoustical measurements performed on the same system¹⁰ do not show any sizeable modification in the fully structured solution, although a relaxation process seems to occur during the building up of the thyxotropic structure. As a consequence we believe that actually we are looking at the vibrational behaviour of the fluctuations of concentration. From preceding measurements we know that some Fourier components of such fluctuations, with very long decay time, are the main contribution to the spectrum, giving rise to a well defined structure factor $S(k)$. On the other hand a solid-like behaviour of the structure reveals itself in rheological measurements: provided that the strain does not exceed a given value, the system is able to behave as an elastic body. The possibility that the dynamics of concentration fluctuations could give rise to propagating interdiffusive modes was already pointed out in a simulated experiment on the Li-Pb liquid alloy¹¹. Authors suggest that the mode could be interpreted as a collective oscillation of the light Li atoms around immobile and heavy Pb atoms.

In our case, the same thyxotropic structure could be able to sustain vibrational modes: the larger is the rigidity of the structure the higher is the frequency of the mode.

According to Ref. 8 the frequency shift ω_B can be written as:

$$\omega_B = c_0 k \left(1 - \frac{\Gamma}{dc_0} \left((1 + k^2 d^2)^{1/2} - 1 \right) \right) \quad (3)$$

where c_0 , the "ideal" sound velocity, in absence of damping, is related to the compressibility of the system:

$$c_0^2 = \frac{K_T}{\rho}$$

while

$$\Gamma = \frac{1}{2} \left(b + \frac{\gamma - 1}{\gamma} a \right)$$

$$d = \frac{1}{2c_0} \left(b + 3 \frac{\gamma - 1}{\gamma} a \right)$$

where a is the contribution to the damping due to the thermal conductivity, b refers to the contribution of shear and bulk viscosity and γ is the ratio C_p/C_v .

If one neglects the usually small contribution due to the thermal conductivity, Eq. 3 reduces to:

$$\omega_B = c_0 k \left(1 - \frac{k^2 b^2}{8c_0} + O(k^4) \right) \quad (4)$$

Now our system turns out to be very peculiar as far as viscosity effects are concerned.

As mentioned before, some Fourier components of concentration fluctuations are long-lived and dominate the structure factor $S(k)$ of the macromolecular distribution. Now, if the wave-vector of a standing wave matches the values corresponding to maxima in the $S(k)$, in such a way that higher concentration regions fall in the nodal position of the wave, the latter will experience a greatly reduced damping. According to Eq. 4, a decrease of the value of b will result in an increase of the phase velocity of the wave. A rough evaluation of the intensity effect can be made by assuming that the latter becomes negligible for k values that match the maxima of the structure factor. In such a case the experimentally found values of velocity (~ 2500 m/sec) would correspond to undamped waves. On the contrary, the stronger damping effects would correspond to the lower value of the phase velocity (~ 1500 m/sec). From Eq. 4 one can then evaluate the corresponding value of the parameter

$$b = \left(\frac{4}{3} \eta_s + \eta_v \right) / \rho$$

It turns out $b \simeq 2.6$ poise, that favourable compares with the viscosity values experimentally found in rheological measurements for vanishingly small shear rate.

4 CONCLUDING REMARKS

We measured the vibrational frequency of the fluctuations of concentration of macromolecules in water. Such a frequency turns out to be higher than that pertaining to bulk water, and can be interpreted as a higher phase velocity, due to the higher rigidity of the thyxotropic structure. Such a phase velocity turns out to be k -dependent, via the viscous damping that takes place as a consequence of the motion of the structure relatively to the embedding medium.

From the present results it follows that the fluctuations of concentration can show a vibrational dynamical behaviour together with the usual diffusional properties. Like the latter, the frequency of the former strongly depends on the wave-vector in such a way that those components characterized by a longer lifetime ($\Gamma^{-1} = (k^2 D(K))^{-1}$) also show a higher vibrational frequency. A similar behaviour has been shown in strong electrolytic solutions¹², in which also exists a solid-like local structure reproducing that of the hydrated crystal, and predicted in a simulation experiment on a Li-Pb alloy¹¹.

It is also to be mentioned that recent results in inelastic neutron scattering experiments in macromolecular solutions⁷ showed a sizeable increase of the “effective mass” of the scatterers (hydrogen atoms), that mimics the extent of the rigidity of the surrounding medium, that takes place as the thyxotropic structure is built up.

References

1. R. Giordano, M. P. Fontana, F. Wanderlingh; *J. Chem. Phys.*, **74**, 2011 (1981).
2. R. Giordano *et al.*; *J. Chem. Phys.*, **75**, 4770 (1981).
3. J. C. Brown, P. N. Pusey, J. W. Goodwin and R. M. Otterwill; *J. Phys. A*, **8**, 664 (1975).
4. R. Giordano, F. Mallamace, N. Micali, F. Wanderlingh, G. Baldini, S. Doglia; *Phys. Rev.*, **28**, 3581 (1983).
5. F. Farsaci, M. E. Fontanella, G. Salvato, F. Wanderlingh, R. Giordano, U. Wanderlingh; *Phys. Chem. Liq.*, **20**, 205 (1989).
6. G. Careri, E. Gratton; “The statistical time correlation approach to enzyme action: the role of hydration”, in “*The fluctuating enzyme*”; G. R. Welch ed. (J. Wiley and Sons, N. York, 1986).
7. R. Giordano *et al.*; *Phys. Rev. A*, **41**, **2**, 689 (1990).
8. W. A. B. Evans and J. G. Powles; *J. Phys. A*, **7**, 1944 (1974).
9. R. D. Mountain; *Rev. Mod. Phys.*, **38**, 205 (1966).
10. R. Giordano, F. Mallamace, F. Wanderlingh; *Il Nuovo Cimento*, **2D**, 1272 (1983).
11. G. Iacucci and M. Ronchetti; *J. Physique*, **46** C8, 385 (1985); see also M. Rovere and M. P. Tosi; *Rep. on Progr. in Phys.*, **46**, 1063 (1986).
12. M. P. Fontana *et al.*; *Solid State Comm.*, **23**, 489 (1977).